

Zhaga Interface Specification

Book 7
Edition 1.3
April 2015

**Rectangular non-socketable LLE with
undefined LES and Separate ECG**



Zhaga Interface Specification Book 7

Summary (informative)

Background

The Zhaga Consortium is a worldwide organization that aims to standardize LED light engines.

The Zhaga Interface Specification consists of a series of books, which have been approved by the general assembly of the Zhaga Consortium. Each book defines a LED light engine by means of its mechanical, photometric, electrical, thermal, and control interfaces to a luminaire. This makes the LED light engines interchangeable in the sense that is easy to replace one LED light engine with another, even if they have been made by different manufacturers.

The Zhaga Interface Specification distinguishes between four kinds of LED light engines, namely:

- socketable with integrated electronic control gear.
- socketable with separate electronic control gear.
- non-socketable with Integrated electronic control gear.
- non-socketable with Separate electronic control gear.

Contents

This book 7 of the Zhaga Interface Specification defines several non-socketable LED light engines with separate electronic control gear. Each LED Light Engine has a rectangular shape and the only restriction to the light emitting surface is that no light is emitted in the direction of the reference plane of the LED module.

This book must be read together with book 1 of the Zhaga Interface Specification.

Intended Use

The Book-7 LED light engine can be mounted in a luminaire, for example by means of screws. Book-7 LED Light Engines are intended to be replaced by professionals only.



Zhaga Interface Specification

Book 7: Rectangular non-socketable LLE with undefined LES and Separate ECG

Edition 1.3

April 2015

COPYRIGHT

The Zhaga Interface Specification is published by the Zhaga Consortium, and has been prepared by the members of the Zhaga Consortium. All rights are reserved. Reproduction in whole or in part is prohibited without express and prior written permission of the Zhaga Consortium.

DISCLAIMER

The information contained herein is believed to be accurate as of the date of publication. However, neither the Zhaga Consortium, nor any member of the Zhaga Consortium will be liable for any damages, including indirect or consequential, from use of the Zhaga Interface Specification or reliance on the accuracy of this document.

CLASSIFICATION

The information contained in this document is for public use.

NOTICE

For any further explanation of the contents of this document, or in case of any perceived inconsistency or ambiguity of interpretation, visit www.zhagastandard.org or contact info@zhagastandard.org.

Table of Contents

1	General.....	1
1.1	Introduction.....	1
1.2	Scope (informative).....	1
1.3	Main features (informative)	1
1.4	Conformance and References	1
1.4.1	Conformance	1
1.4.2	References.....	1
1.5	Definitions	1
1.6	Acronyms	2
1.7	Symbols.....	2
1.8	Conventions	2
1.8.1	Precedence.....	2
1.8.2	Cross references	2
1.8.3	Informative text.....	2
1.8.4	Terms in capitals	2
1.8.5	Units of physical quantities	2
1.8.6	Decimal separator.....	2
1.8.7	Limits.....	2
2	System Overview (informative)	3
2.1	Structure of a Zhaga book.....	3
3	Mechanical Interface.....	4
3.1	Drawing principles	4
3.2	Book-7 LLE categories.....	4
3.2.1	L6W6.....	5
3.2.2	L28W2.....	7
3.2.3	L28W4.....	9
3.2.4	L28W6.....	11
3.2.5	L28W28.....	13
3.2.6	L38W38.....	15
3.2.7	L56W56.....	17
3.2.8	L56W2.....	19
3.2.9	L56W4.....	21
3.3	Requirements on the mechanical interface of the Book-7 Luminaire	23
3.3.1	Flatness and roughness of the Thermal Interface Surface	23
3.3.2	Luminaire keep-out for interconnect.....	23
3.3.3	Luminaire ECG mounting surface	23
3.4	Mechanical dimensions of ECG.....	23
4	Photometric Interface.....	24
4.1	Light Emitting Surface.....	24
4.2	Operating conditions for measuring photometric parameters.....	24
4.3	Luminous flux.....	24
4.4	Luminous intensity distribution.....	24

4.5	Luminance uniformity.....	24
4.6	Correlated color temperature (CCT).....	25
4.7	Color rendering index (CRI)	25
5	Electrical Interface.....	26
5.1	Electrical insulation.....	26
6	Thermal Interface	27
6.1	Background information (informative).....	27
6.2	General thermal requirements for Book-7 LLEs.....	27
6.3	Thermal headroom of Book-7 LLEs	27
7	Control Interface.....	28
Annex A	Compliance tests	29
A.1	LLE compliance tests	29
A.1.1	LLE mechanical interface tests	29
A.1.2	LLE photometric interface tests	29
A.1.3	LLE thermal interface tests.....	31
A.1.4	LLE electrical interface tests.....	35
A.1.5	LLE control interface tests	35
A.1.6	LLE Product Data Set test.....	35
A.2	Luminaire compliance tests.....	36
A.2.1	Luminaire mechanical interface tests.....	36
A.2.2	Luminaire photometric interface tests.....	36
A.2.3	Luminaire electrical interface tests	36
A.2.4	Luminaire thermal interface tests.....	36
A.2.5	Luminaire control interface tests	37
A.2.6	Luminaire Product Data Set test	37
Annex B	Product Data Set Requirements.....	38
B.1	LLE Product Data Set	38
B.2	Luminaire Product Data Set.....	38
Annex C	Measurements on Luminance uniformity (informative)	39
C.1	Test equipment.....	39
C.2	Test conditions	39
C.3	Test procedure.....	40
Annex D	Guidelines for mechanical interface test (informative)	41
Annex E	History of Changes.....	43

List of Figures

Figure 2-1: Example of an LLE – Luminaire combination with a single LLE and two LED Modules	3
Figure 3-1: LED Module Demarcation and Luminaire Demarcation of the L6W6 category.	6
Figure 3-2: LED Module Demarcation and Luminaire Demarcation of the L28W2 category.....	8
Figure 3-3: LED Module Demarcation and Luminaire Demarcation of the L28W4 category.....	10
Figure 3-4: LED Module Demarcation and Luminaire Demarcation of the L28W6 category.....	12
Figure 3-5: LED Module Demarcation and Luminaire Demarcation of the L28W28 category.....	14
Figure 3-6: LED Module Demarcation and Luminaire Demarcation of the L38W38 category.....	16
Figure 3-7: LED Module Demarcation and Luminaire Demarcation of the L56W56 category.....	18
Figure 3-8: LED Module Demarcation and Luminaire Demarcation of the L56W2 category.....	20
Figure 3-9: LED Module Demarcation and Luminaire Demarcation of the L56W4 category.....	22
Figure 4-1: Set-up for luminance uniformity measurement.	25
Figure A-1: Test Fixture	31
Figure A-2: Mechanical dimensions of frame.....	32
Figure A-3: Mechanical dimensions of back plate.....	33
Figure A-4: Mechanical dimensions of the cover plate.	34
Figure C-1: Set-up for luminance uniformity measurement.	39
Figure D-1: Example of a LED Module.....	41
Figure D-2: Example of a LED Module with sections.....	41
Figure D-3: Example of a LED Module with measurement points.....	42

List of Tables

Table 3-1: LED Module Demarcation and Luminaire Demarcation of the L6W6 category.	5
Table 3-2: LED Module Demarcation and Luminaire Demarcation of the L28W2 category.	7
Table 3-3: LED Module Demarcation and Luminaire Demarcation of the L28W4 category.	9
Table 3-4: LED Module Demarcation and Luminaire Demarcation of the L28W6 category.	11
Table 3-5: LED Module Demarcation and Luminaire Demarcation of the L28W28	13
Table 3-6: LED Module Demarcation and Luminaire Demarcation of the L38W38 category.	15
Table 3-7: LED Module Demarcation and Luminaire Demarcation of the L56W56 category.	17
Table 3-8: LED Module Demarcation and Luminaire Demarcation of the L56W2 category.	19
Table 3-9: LED Module Demarcation and Luminaire Demarcation of the L56W4 category.	21
Table 4-1: Luminous flux categories	24
Table A-1: Mechanical dimensions of frame.....	32
Table A-2: Mechanical dimensions of back plate.....	33
Table A-3: Mechanical dimensions of the cover plate.....	34
Table D-1: Changes from Edition 1.2 to Edition 1.3.	43

1 General

1.1 Introduction

For the purpose of this section, [Book 1] – section 1.1, applies.

1.2 Scope (informative)

This Book 7 defines the interfaces between a LED Light Engine and a Luminaire. Also, for the purpose of this section, [Book 1] - section 1.2, applies.

1.3 Main features (informative)

This Book 7 defines a LED Light Engine, which can be fixed in a Luminaire. This document defines:

- Nine categories of the LED Light Engines.
- Luminaires that provide the appropriate environment for the Book-7 LED Light Engine(s).

All Book-7 LED Modules have a rectangular shape and the only restriction to the light emitting surface is that that no light is emitted in the direction of the reference plane of the LED Module.

1.4 Conformance and References

1.4.1 Conformance

All provisions in the Zhaga interface Specification are mandatory, unless specifically indicated as recommended, optional or informative. Verbal expressions of provisions in the Zhaga Interface Specification follow the rules provided in Annex H of ISO/IEC Directives, Part 2. For clarity, the word “shall” indicates a requirement that is to be followed strictly in order to conform to the Zhaga Interface Specification, and from which no deviation is permitted. The word “should” indicates that among several possibilities one is recommended as particularly suitable, without mentioning or excluding others, or that a certain course of action is preferred but not necessarily required, or that (in the negative form) a certain possibility or course of action is deprecated but not prohibited. The word “may” indicates a course of action permissible within the limits of the Zhaga Interface Specification. The word “can” indicates a possibility or capability, whether material, physical or causal.

1.4.2 References

For references that are not listed in this section, see [Book 1]. For undated references, the most recently published edition applies.

[Book 1]	Zhaga Interface Specification, Book 1: Overview and Common Information.
[ISO-IEC 15948]	International Standard 15948:2003 -- Portable Network Graphics (PNG): Functional specification.
[IEC 60598]	Luminaires—Part 1: General requirements and tests, IEC 60598-1.

1.5 Definitions

For the purpose of this section, the definitions of [Book 1] - section 1.4, apply. In addition, the following definitions also apply to this Book 7 of the Zhaga Interface Specification.

Book-7 LED Light Engine	LED Light Engine according to the specifications in this book.
Uniformity Test Diffuser	Diffuser plate that is used for measuring luminance uniformity.
LED Module Demarcation	The mechanical boundary between a LED Module and its environment consisting of a Luminaire and interconnect.
Luminaire Demarcation	The mechanical boundary between a Luminaire and its environment consisting of a LED Module and interconnect.

1.6 Acronyms

For the purpose of this section, the acronyms of [Book 1] - section 1.5, apply. In addition, the following acronyms also apply to this Book 7 of the Zhaga Interface Specification.

UTD Uniformity Test Diffuser

1.7 Symbols

For the purpose of this section, the symbols of [Book 1] - section 1.6, apply. In addition, the following symbols definitions also apply to this Book 7 of the Zhaga Interface Specification.

d_{UTD} Distance between the mounting plate and the UTD (unit: mm).
 t_p Temperature at a specific point on the LED Module (unit: °C).
 $t_{p,normal}$ Value of the temperature t_p at normal operating conditions (see section A.1.3.1; unit: °C).
 $t_{p,max}$ Value of the temperature t_p at which the Rated LLE values are specified (unit: °C).
 $t_{p,headroom}$ = $t_{p,max} - t_{p,normal}$ (unit: °C).

1.8 Conventions

This section defines the notations and conventions used in the Zhaga Interface Specification.

1.8.1 Precedence

In the case of any perceived discrepancy between the definitions provided in chapters 1 to 7 of this document and the definitions provided in Annex A of this document, the definitions provided in Annex A take precedence over the definitions provided in chapters 1 to 7.

1.8.2 Cross references

Unless indicated otherwise, cross references to sections include the sub sections contained therein.

1.8.3 Informative text

Informative text is set in italics, unless the whole section is marked as informative.

1.8.4 Terms in capitals

Terms that have a specific meaning in the context of this Book 7 are capitalized. See section 1.5.

1.8.5 Units of physical quantities

Physical quantities are expressed in units of the International System of Units. All lengths that omit an explicit unit indication are in millimeters.

1.8.6 Decimal separator

The decimal separator is a comma.

1.8.7 Limits

Values that are indicated as typical, as well as values between parentheses, are informative.

2 System Overview (informative)

For the purpose of this section, the system overview of [Book 1], Section 2, applies. In addition, the following general remarks apply.

This Book 7 of the Zhaga Interface Specification defines several categories of LED Light Engines consisting of one or more LED Modules and an Electronic Control Gear physically separated from each other. The LED Modules and the ECG are intended to be mounted in a Luminaire. Book-7 LLEs are intended to be replaced by professionals only. The connection between the LED Module(s) and the ECG is not defined by Zhaga and shall be implemented according to the instructions of the LED Light Engine manufacturer. Figure 2-1 illustrates an example of an LLE-Luminaire combination. In this example the Luminaire holds one LLE and the LLE has two LED Modules. In practice, a Luminaire may hold any number of LLEs with any number of LED Modules.

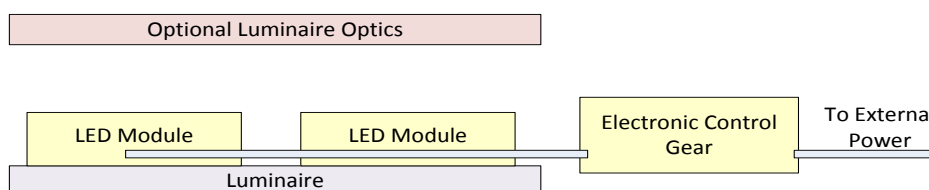

Figure 2-1: Example of an LLE – Luminaire combination with a single LLE and two LED Modules

The Luminaire typically features Luminaire Optics which shape the light output of the LLE. The photometric interface of the Book-7 LLE is specified in such a way that using suitable Luminaire Optics, similar Luminaire performance is to be expected in typical applications using different LLEs with the same luminance uniformity. The specification has been carefully evaluated to yield as much as possible “similar” performance without restricting the LED technology or the inner structure of the LLE.

2.1 Structure of a Zhaga book

In sections 3, 4, 5, 6 and 7 the mechanical, photometric, electrical, thermal and control interfaces are defined. Annex A defines the Zhaga compliance tests for both LED Light Engines and Luminaires. Annex B defines the requirements for the Product Data Sets. Annexes C and D hold guidelines for photometric and mechanical measurements respectively and annex E holds a list of changes with respect to the previous edition of the book.

3 Mechanical Interface

3.1 Drawing principles

For the purpose of this section, the provisions in [Book 1] - section 3.1, apply.

3.2 Book-7 LLE categories

This Book 7 of the Zhaga Interface Specification specifies a number of LLE categories that are identified by a designation. In the following sub sections, the LED Module Demarcations and Luminaire Demarcations of these Book-7 LLE categories are specified.

No part of a LED Module shall cross the outline boundaries of the corresponding LED Module Demarcation. And no part of a Luminaire shall cross the outline boundaries of the corresponding Luminaire Demarcation.

Unless stated otherwise, all holes shall be available and for each hole at least 25% of the circumference of the hole shall be present in the LED Module.

In case the LED Module is applied in combination with a Thermal Interface Material, this material is defined to be part of the LED module. Thus the total height of the Module + TIM shall not exceed the maximum height H.

Additionally, for the purpose of this section, the provisions in [Book 1] - section 3.3, apply.

3.2.1 L6W6

The LED Module Demarcation and Luminaire Demarcation of the L6W6 category are defined in Figure 3-1 and Table 3-1. The designation for this category is 'L6W6'.

dimension	Value
L	60
W	60
H	20
a	48
b	48
M	20
P	35
Øc	4,3

Table 3-1: LED Module Demarcation and Luminaire Demarcation of the L6W6 category.

Notes to Figure 3-1:

- X-axis is symmetry axis for the outline and the mounting holes.
- Y-axis is symmetry axis for the outline and the mounting holes.
- The hashed area indicates the keep-in zone for the LED Module and the keep-out zone for the Luminaire.

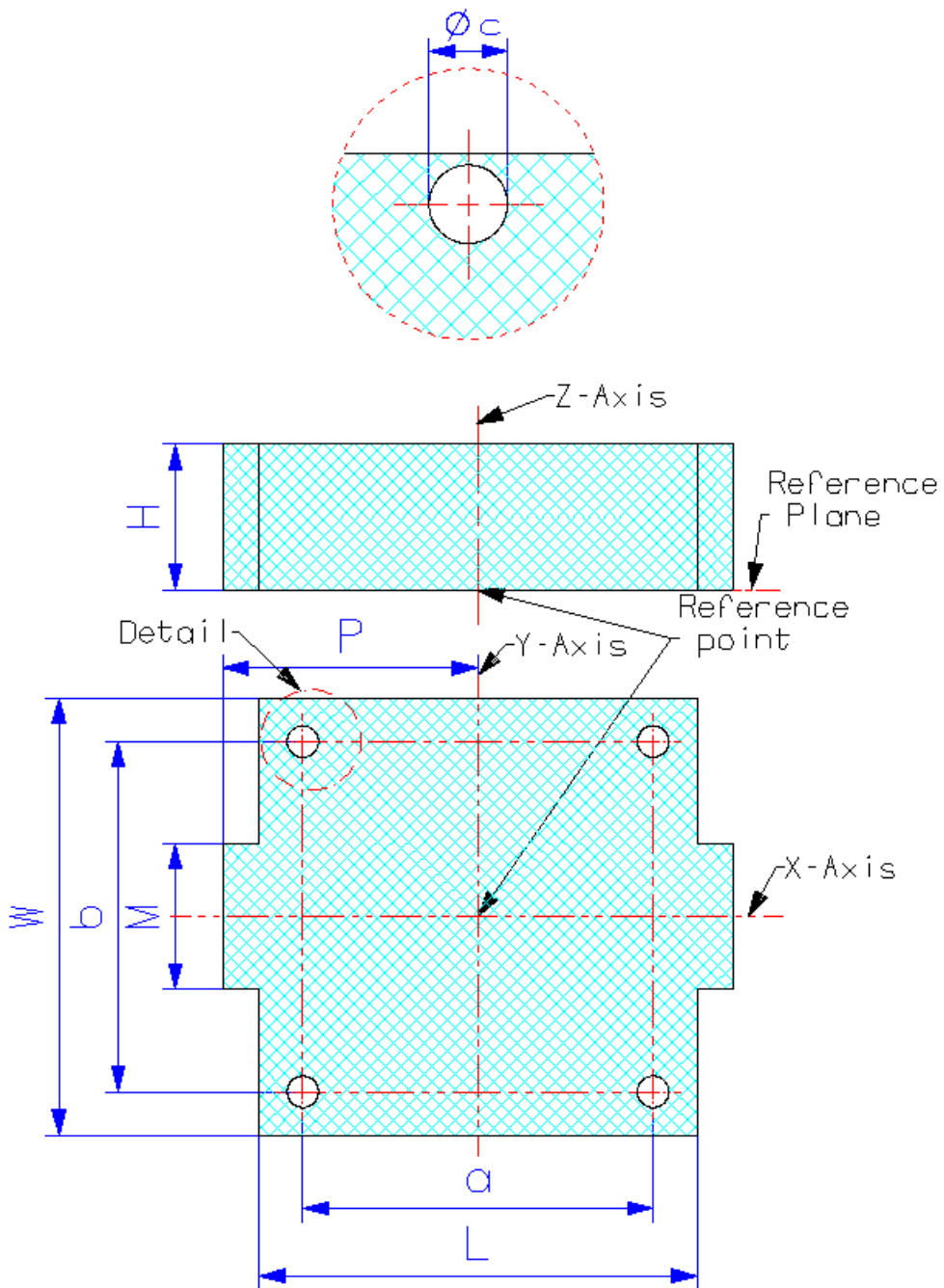

Figure 3-1: LED Module Demarcation and Luminaire Demarcation of the L6W6 category.

The top figure shows the detail.

3.2.2 L28W2

The LED Module Demarcation and Luminaire Demarcation of the L28W2 category are defined in Figure 3-2 and Table 3-2. The two mounting holes at the bottom of the diagram of Figure 3-2 are optional for the LLE but mandatory for the Luminaire. The designation for this category is 'L28W2'.

dimension	Value
L	280
W	24
H	20
a	125
b	18,4
Øc	4,3

Table 3-2: LED Module Demarcation and Luminaire Demarcation of the L28W2 category.

Notes to Figure 3-2:

- X-axis is symmetry axis for the outline and the cross-hair lines of the mounting holes.
- Y-axis is symmetry axis for the outline and mounting holes.
- The hashed area indicates the keep-in zone for the LED Module and the keep-out zone for the Luminaire.

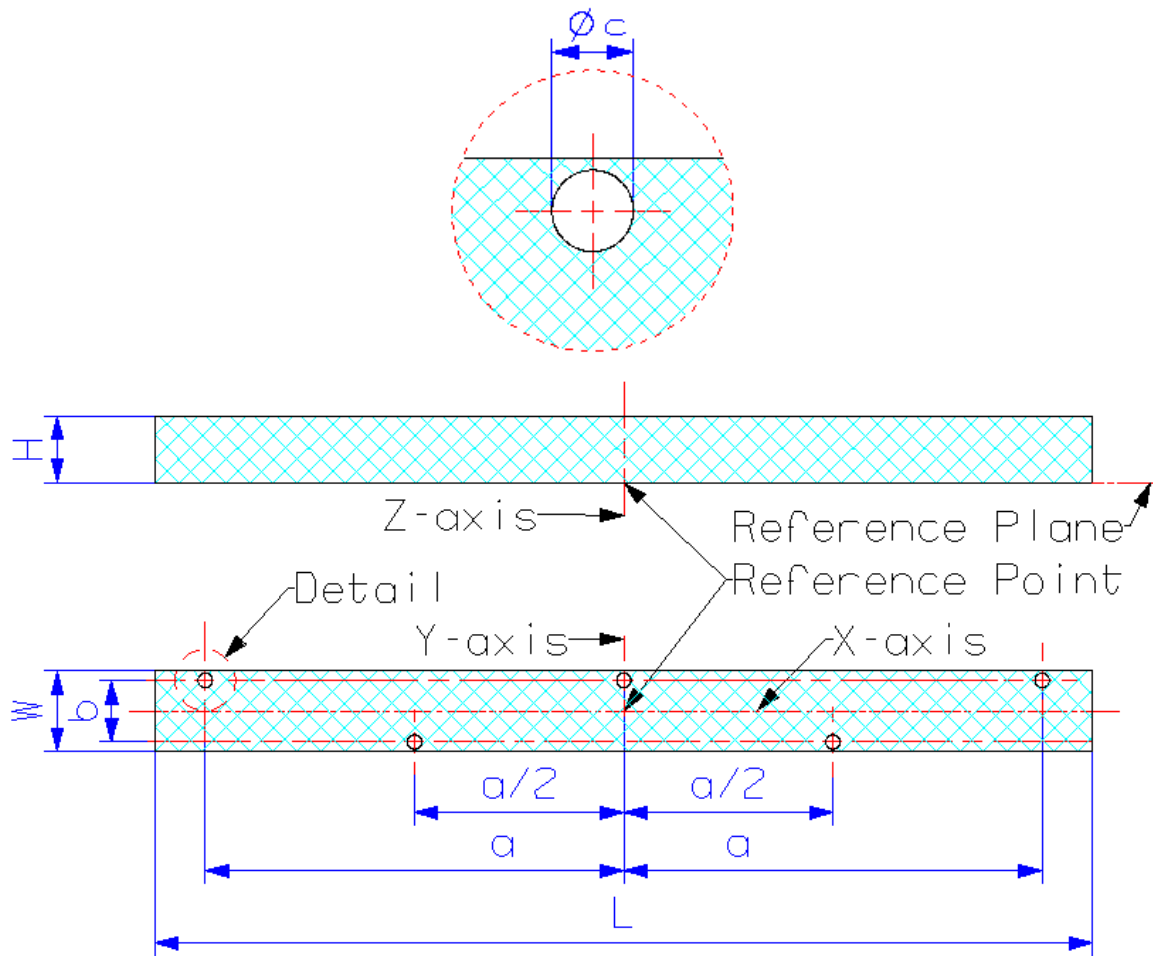

Figure 3-2: LED Module Demarcation and Luminaire Demarcation of the L28W2 category.

The top figure shows the detail.

3.2.3 L28W4

The LED Module Demarcation and Luminaire Demarcation of the L28W4 category are defined in Figure 3-3 and Table 3-3. The designation for this category is 'L28W4'.

dimension	Value
L	281
W	41
H	20
a	110
b	31
$\varnothing c$	4,3

Table 3-3: LED Module Demarcation and Luminaire Demarcation of the L28W4 category.

Notes to Figure 3-3:

- X-axis is symmetry axis for the outline and the cross-hair lines of the mounting holes.
- Y-axis is symmetry axis for the outline and mounting holes.
- The hashed area indicates the keep-in zone for the LED Module and the keep-out zone for the Luminaire.

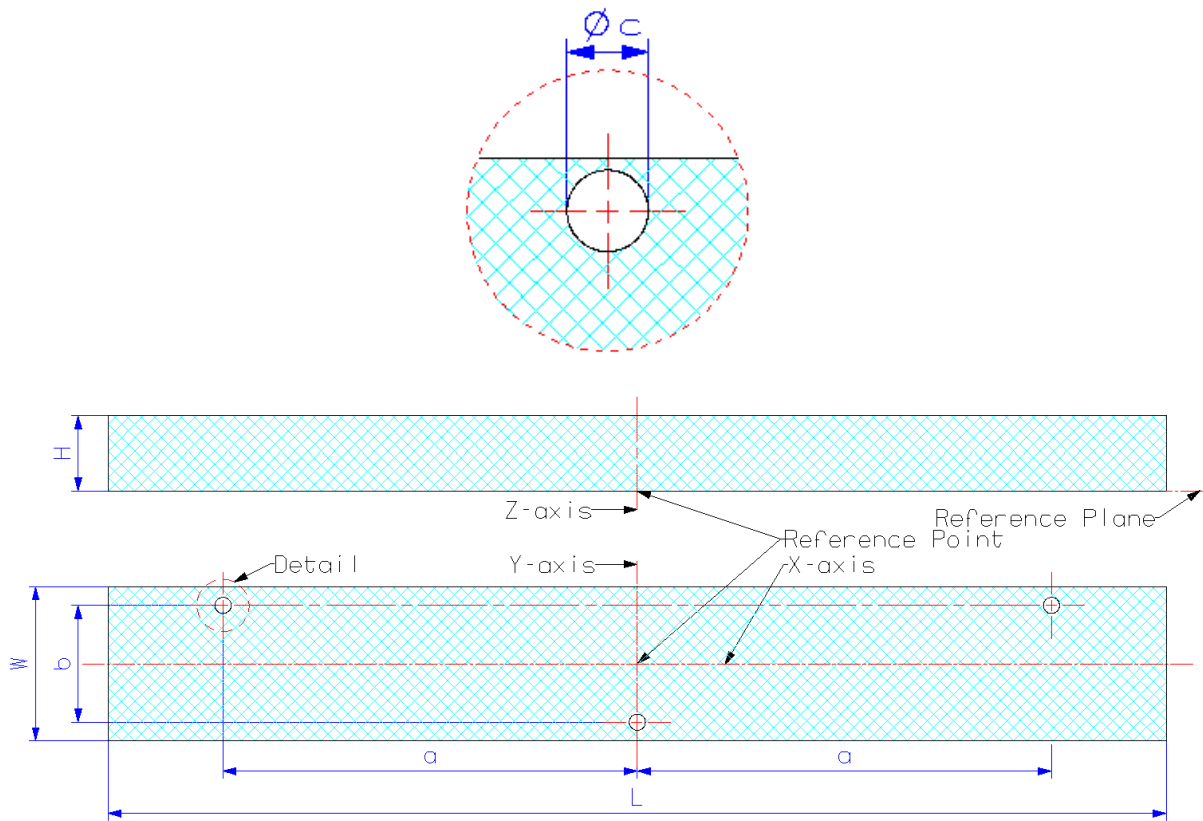

Figure 3-3: LED Module Demarcation and Luminaire Demarcation of the L28W4 category.

The top figure shows the detail.

3.2.4 L28W6

The LED Module Demarcation and Luminaire Demarcation of the L28W6 category are defined in Figure 3-4 and Table 3-4. The designation for this category is 'L28W6'.

dimension	Value
L	281
W	61
H	20
a	91
b	40
∅c	4,3
d	11
e	15

Table 3-4: LED Module Demarcation and Luminaire Demarcation of the L28W6 category.

Notes to Figure 3-4:

- X-axis is symmetry axis for the outline and the cross-hair lines of the mounting holes.
- Y-axis is symmetry axis for the outline and the left- and rightmost mounting holes.
- The hashed area indicates the keep-in zone for the LED Module and the keep-out zone for the Luminaire.

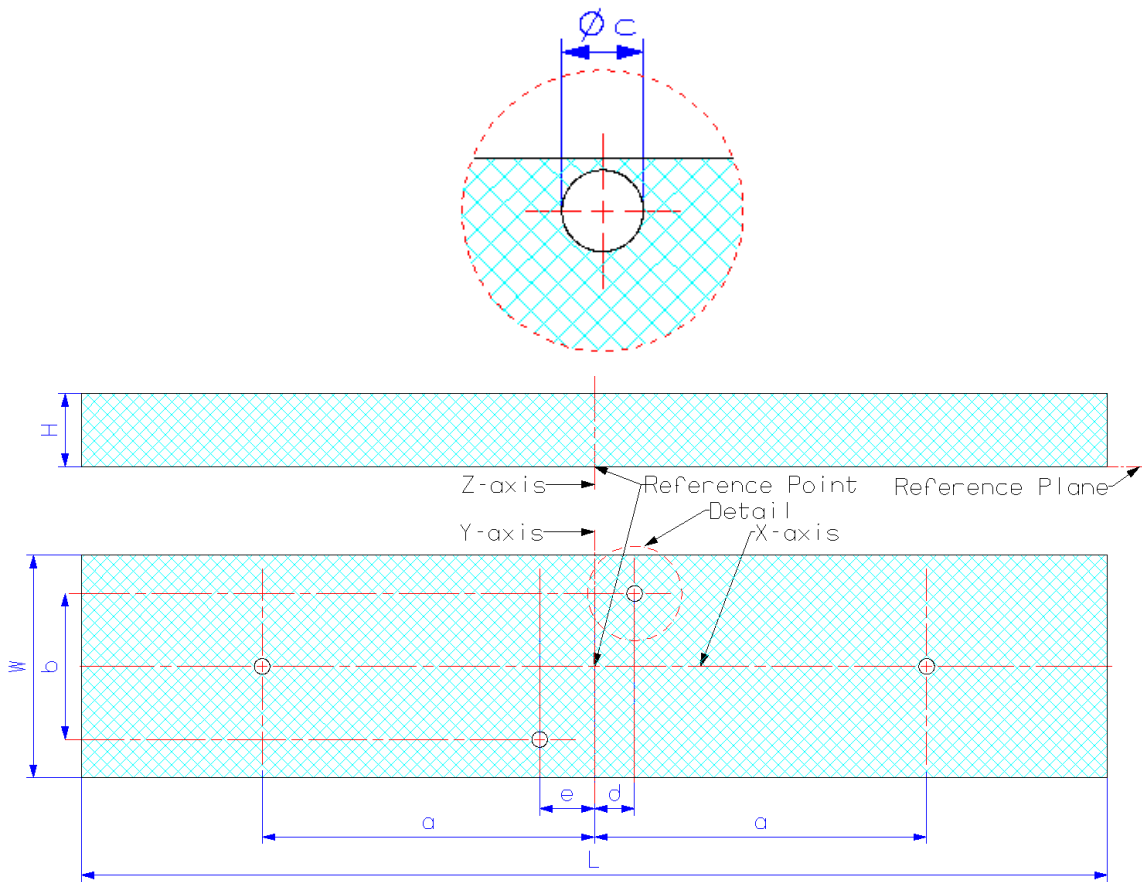

Figure 3-4: LED Module Demarcation and Luminaire Demarcation of the L28W6 category.

The top figure shows the detail.

3.2.5 L28W28

The LED Module Demarcation and Luminaire Demarcation of the L28W28 category are defined in Figure 3-5 and Table 3-5. The designation for this category is 'L28W28'.

dimension	Value
L	281
W	281
H	20
a	222
b	180
$\varnothing c$	4,3

Table 3-5: LED Module Demarcation and Luminaire Demarcation of the L28W28

Notes to Figure 3-5:

- X-axis is symmetry axis for the outline and the mounting holes.
- Y-axis is symmetry axis for the outline and the mounting holes.
- The hashed area indicates the keep-in zone for the LED Module and the keep-out zone for the Luminaire.

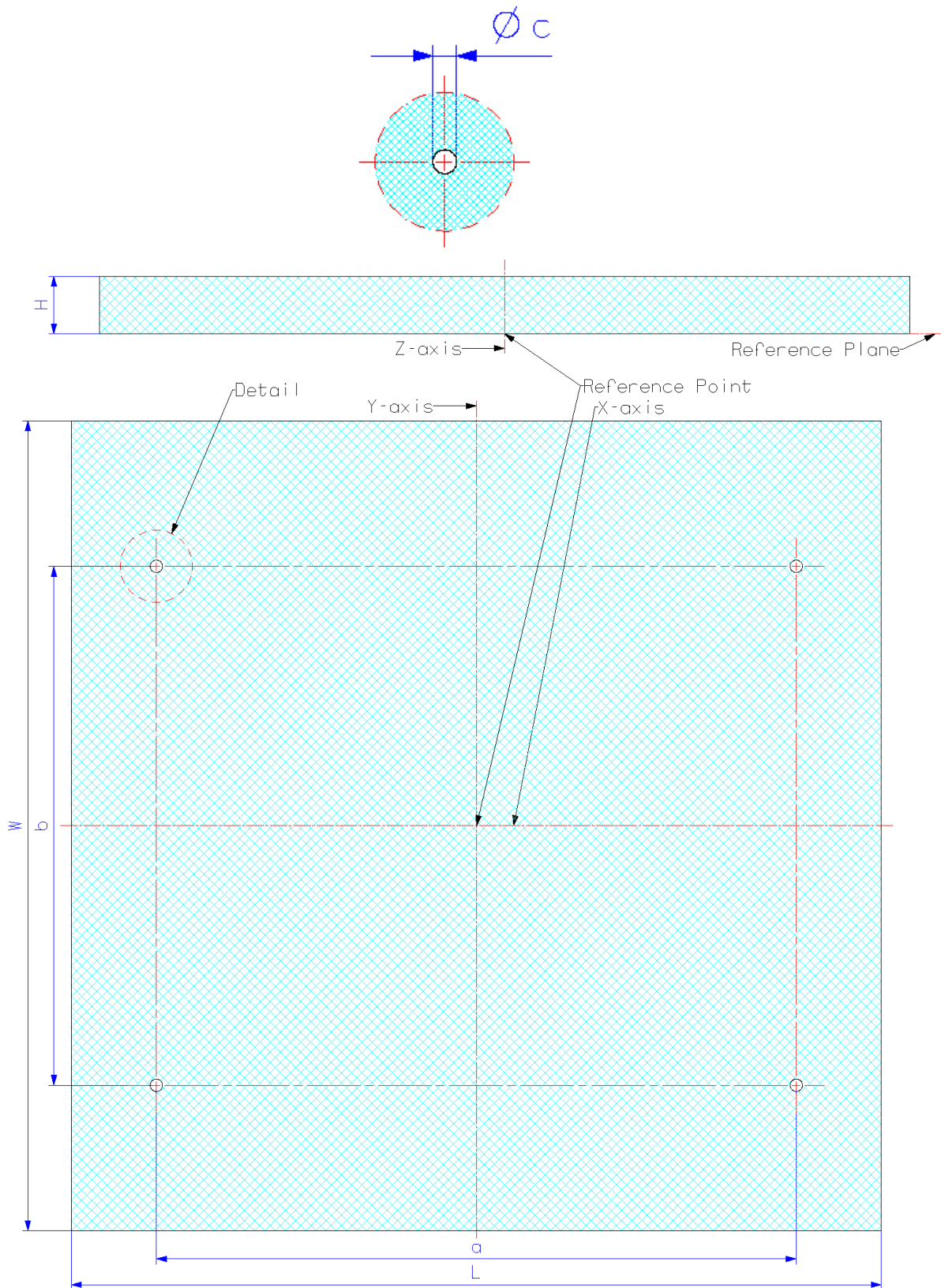

Figure 3-5: LED Module Demarcation and Luminaire Demarcation of the L28W28 category.

The top figure shows the detail.

3.2.6 L38W38

The LED Module Demarcation and Luminaire Demarcation of the L38W38 category are defined in Figure 3-6 and Table 3-7. The four mounting holes in the corners of the diagram of Figure 3-2 are mandatory for LLE and Luminaire. The other mounting holes are optional for the LLE but mandatory for the Luminaire. The designation for this category is 'L38W38'.

dimension	Value
L	381
W	381
H	20
a	371,9
a1	21,3
b	67,2
Øc	4,3

Table 3-6: LED Module Demarcation and Luminaire Demarcation of the L38W38 category.

Notes to Figure 3-6:

- X-axis is symmetry axis for the outline and the mounting holes.
- Y-axis is symmetry axis for the outline and the cross-hair lines of mounting holes.
- The hashed area indicates the keep-in zone for the LED Module and the keep-out zone for the Luminaire.

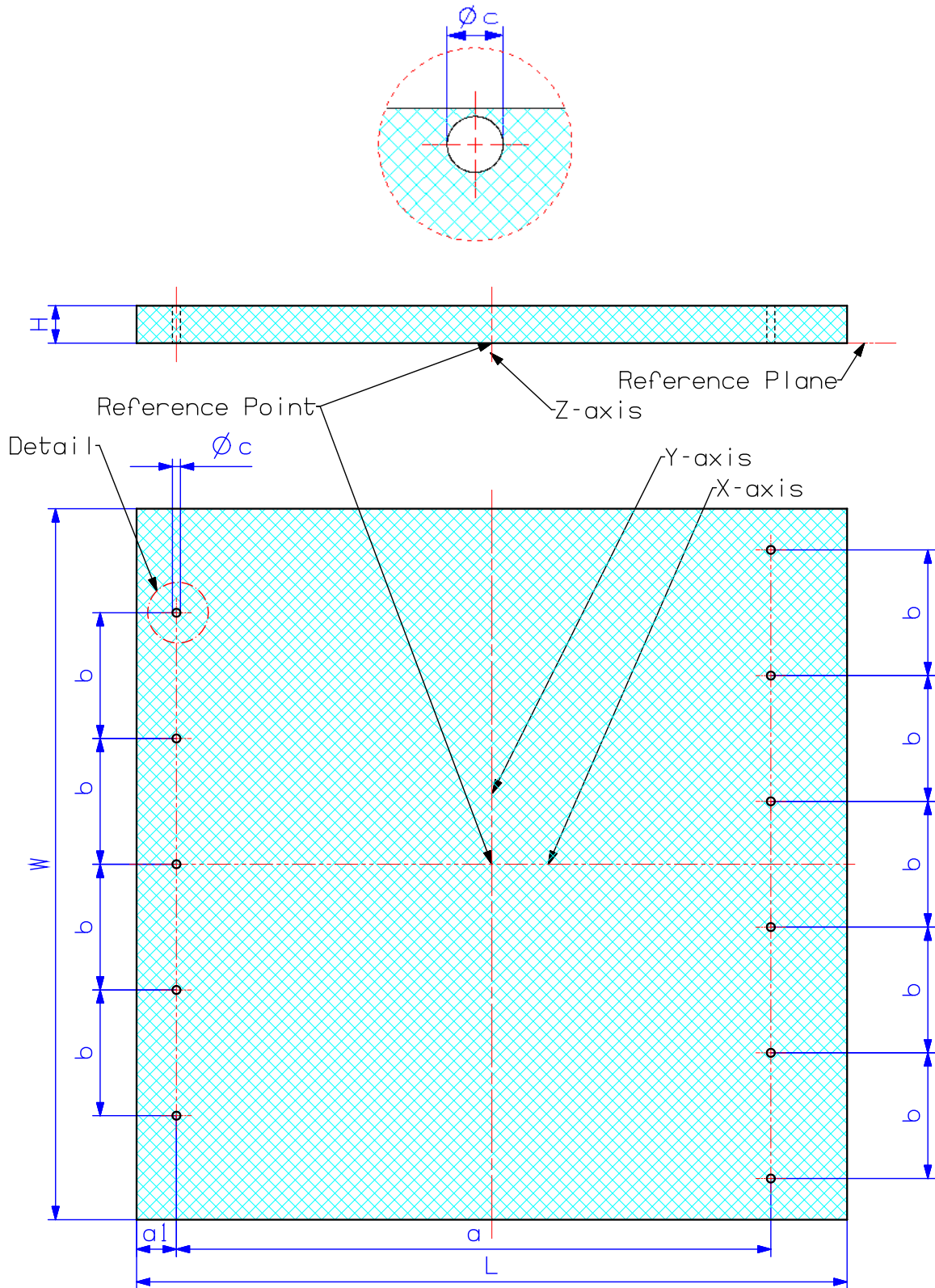

Figure 3-6: LED Module Demarcation and Luminaire Demarcation of the L38W38 category.

The top figure shows the detail.

3.2.7 L56W56

The LED Module Demarcation and Luminaire Demarcation of the L56W56 category are defined in Figure 3-7 and Table 3-7. The designation for this category is 'L56W56'.

dimension	Value
L	562
W	562
H	20
a	503
b	461
∅c	4,3

Table 3-7: LED Module Demarcation and Luminaire Demarcation of the L56W56 category.

Notes to Figure 3-7:

- X-axis is symmetry axis for the outline and the mounting holes.
- Y-axis is symmetry axis for the outline and the mounting holes.
- The hashed area indicates the keep-in zone for the LED Module and the keep-out zone for the Luminaire.

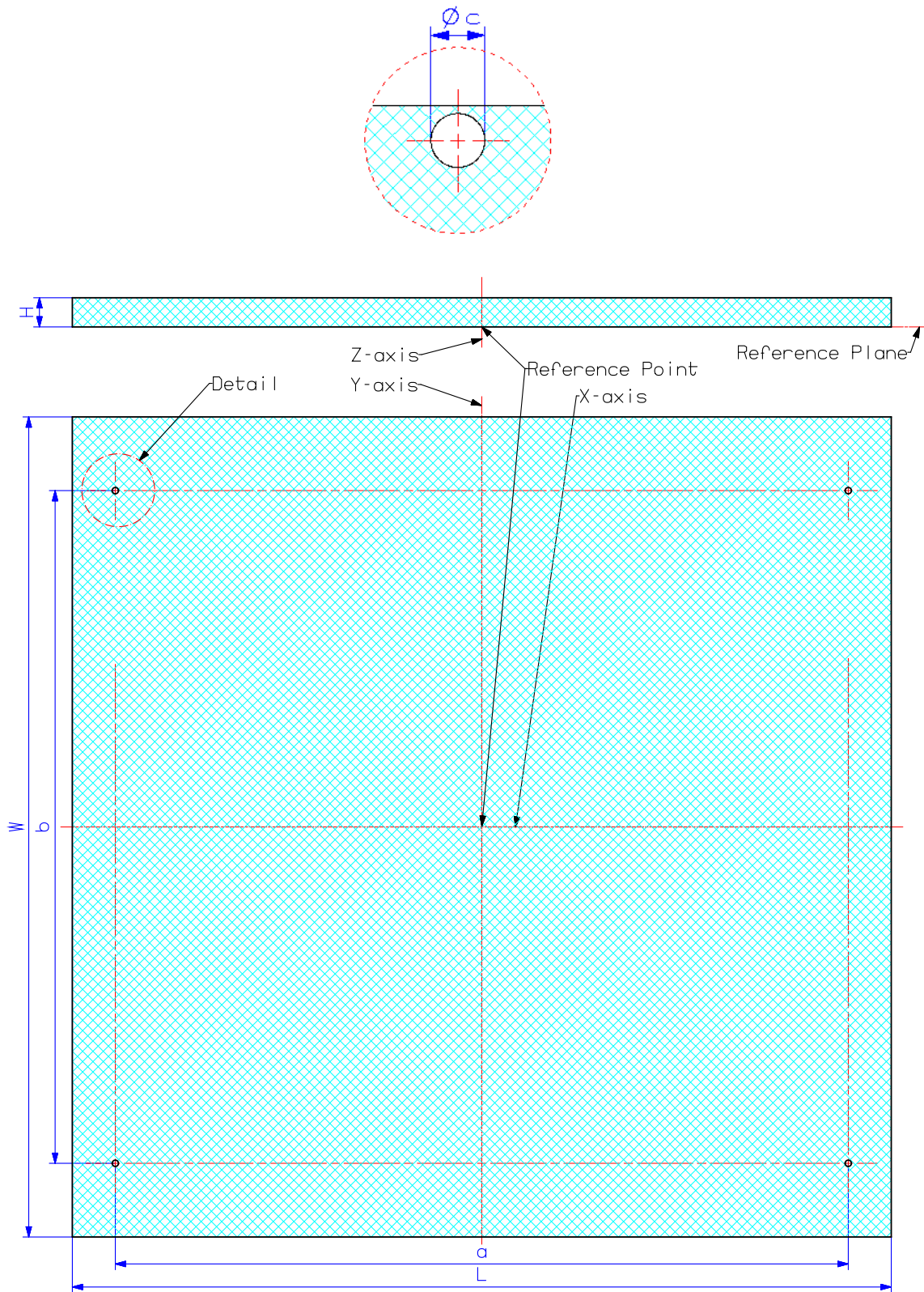

Figure 3-7: LED Module Demarcation and Luminaire Demarcation of the L56W56 category.

The top figure shows the detail.

3.2.8 L56W2

The LED Module Demarcation and Luminaire Demarcation of the L56W2 category are defined in Figure 3-8 and Table 3-8. The four mounting holes at the bottom of the diagram of Figure 3-2 are optional for the LLE but mandatory for the Luminaire. The designation for this category is 'L56W2'.

dimension	Value
L	560
W	24
H	20
a	125
b	18,4
d	30
Øc	4,3

Table 3-8: LED Module Demarcation and Luminaire Demarcation of the L56W2 category.

Notes to Figure 3-9:

- X-axis is symmetry axis for the outline and the cross-hair lines of the mounting holes.
- Y-axis is symmetry axis for the outline and mounting holes.
- The hashed area indicates the keep-in zone for the LED Module and the keep-out zone for the Luminaire.

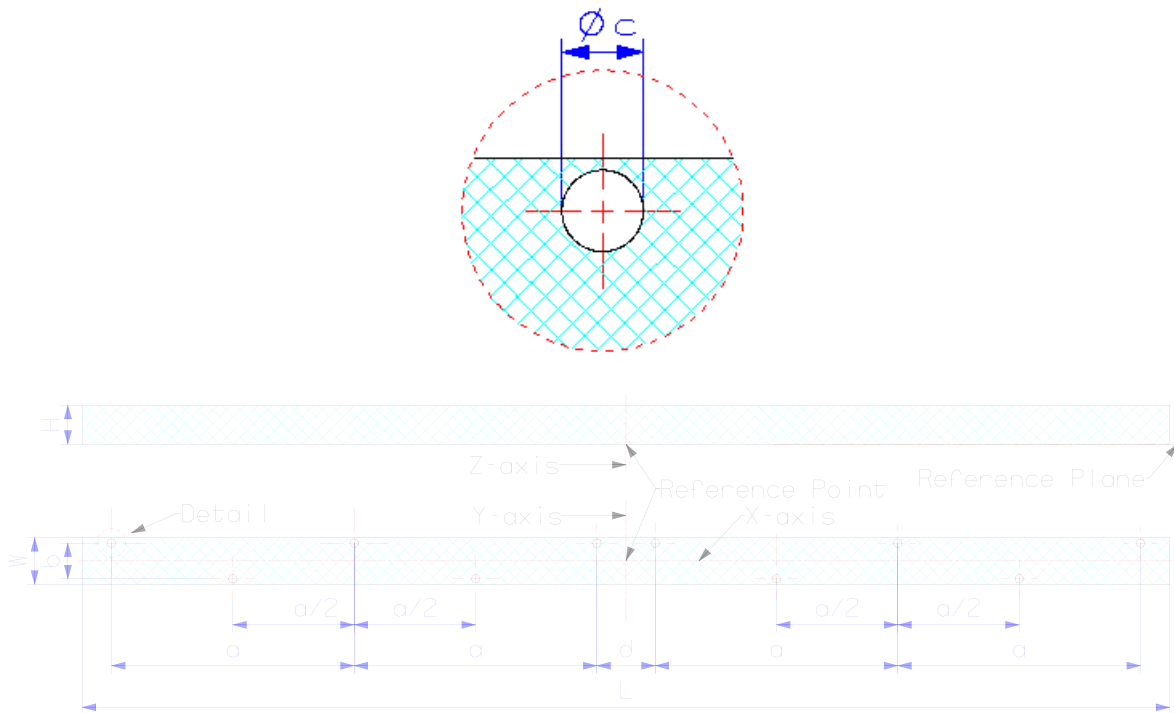

Figure 3-8: LED Module Demarcation and Luminaire Demarcation of the L56W2 category.

The top figure shows the detail.

3.2.9 L56W4

The LED Module Demarcation and Luminaire Demarcation of the L56W4 category are defined in Figure 3-9 and Table 3-9. The designation for this category is 'L56W4'.

dimension	Value
L	561
W	41
H	20
a	110
b	31
∅c	4,3
d	61

Table 3-9: LED Module Demarcation and Luminaire Demarcation of the L56W4 category.

Notes to Figure 3-9:

- X-axis is symmetry axis for the outline and the cross-hair lines of the mounting holes.
- Y-axis is symmetry axis for the outline and mounting holes.
- The hashed area indicates the keep-in zone for the LED Module and the keep-out zone for the Luminaire.

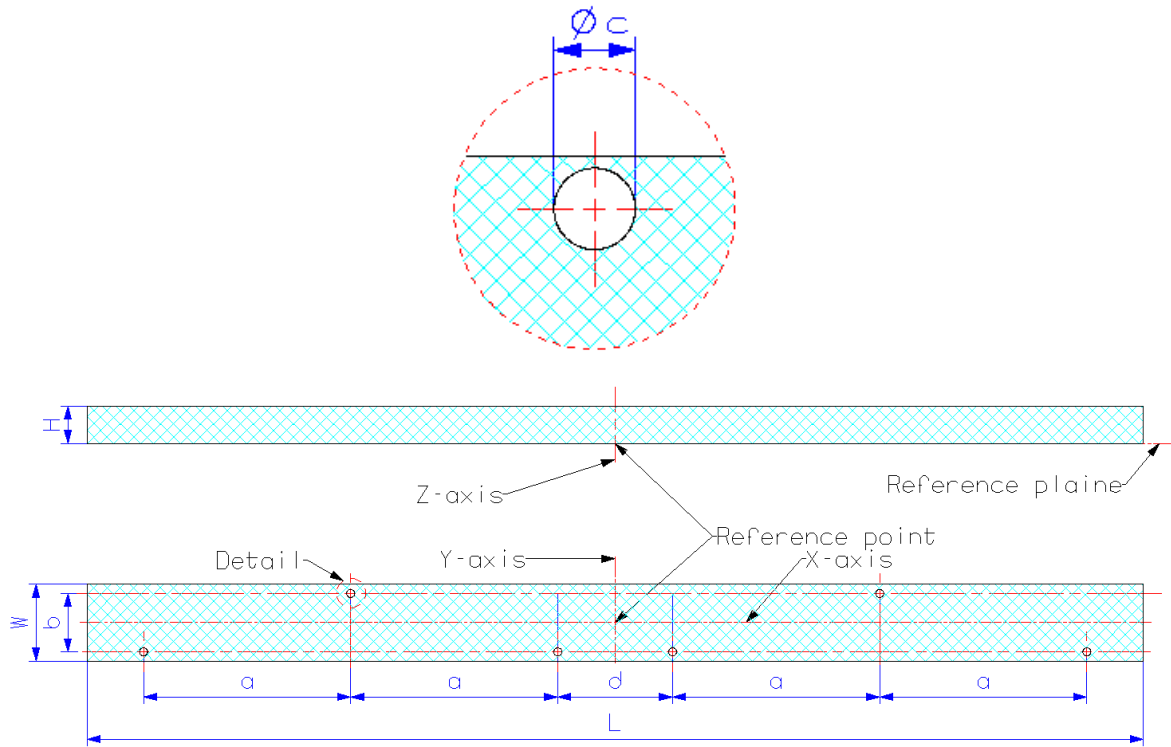

Figure 3-9: LED Module Demarcation and Luminaire Demarcation of the L56W4 category.

The top figure shows the detail.

3.3 Requirements on the mechanical interface of the Book-7 Luminaire

For each LED Module to be mounted in the Luminaire, the Luminaire shall be compliant with the Luminaire demarcation for the corresponding category as defined in section 3.2.

The Product Data Set of the Luminaire shall contain a list of Book-7 LLE categories that can be accommodated in the Luminaire. For each category, the Luminaire Product Data Set shall also contain the number of modules that can be accommodated.

3.3.1 Flatness and roughness of the Thermal Interface Surface

This Edition of Book 7 of the Zhaga Interface Specification does not contain requirements on the flatness and roughness of the Thermal Interface Surface of the Luminaire.

3.3.2 Luminaire keep-out for interconnect

The Luminaire should foresee space for the interconnects between LED Module(s) and ECG and between ECG and external power.

3.3.3 Luminaire ECG mounting surface

For the purpose of this section, the provisions in [Book 1] - section 3.2, apply.

3.4 Mechanical dimensions of ECG

For the purpose of this section, the provisions in [Book 1] - section 3.2, apply.

4 Photometric Interface

4.1 Light Emitting Surface

The Light Emitting Surface of the LLE shall be such that there is no light emitted in the direction of the Reference Plane (see 3.2). This edition of Book 7 of the Zhaga Interface Specification does not contain further requirements on the Light Emitting Surface of the LLE.

4.2 Operating conditions for measuring photometric parameters

For the purpose of this section, the provisions in [Book 1] - section 4.2 apply, with the following exceptions:

- The requirement on t_r does not apply.
- The heat sink(s) of the test fixture(s) shall maintain the temperature (t_p) within the range $t_{p,max} \pm 1$ °C.

4.3 Luminous flux

For the purpose of this section, the provisions in [Book 1] - section 4.3 apply except for the flux categories in [Book 1], table 4-1. The allowed flux categories with corresponding minimum and maximum luminous flux values per luminous flux categories are defined in Table 4-1.

luminous flux category	Minimum luminous flux [lm]	Typical luminous flux [lm]	Maximum luminous flux [lm]
100	85	100	150
200	150	200	250
300	250	300	345
400	340	400	500
600	500	600	690
800	680	800	935
1100	935	1100	1275
1500	1275	1500	1725
2000	1700	2000	2300
2500	2125	2500	2875
3000	2550	3000	3450
4000	3400	4000	4600
5000	4250	5000	5750
6000	5100	6000	6900
7000	5950	7000	8050
8000	6800	8000	9200
10000	8500	10000	11500

Table 4-1: Luminous flux categories

4.4 Luminous intensity distribution

This edition of Book 7 of the Zhaga Interface Specification does not contain requirements on the luminous intensity distribution of the LLE.

4.5 Luminance uniformity

When designing Book-7 LED Modules with multiple LEDs, there is always a trade-off between low LED number and homogeneous fill factor of the module surface. Large LED numbers per area are associated with high luminance uniformity, meaning it is easy to construct a Luminaire where single LEDs are not visible as single bright spots.

In this section a method is described to measure and to evaluate the luminance uniformity of Book-7 LED Modules. This method is specifically designed to compare LED Modules in one idealized application, not to predict LED Modules appearance in any possible application. Rather, if a user has chosen a certain LED Module, he can use the data gathered with the methods described here to estimate if another LED Module will result in similar, “higher” or “lower” luminance uniformity in his application.

Only a single LED Module is measured and assessed. Thus, the acquired data gives only indications about the luminance uniformity of one LED Module.

The measurement setup for luminance uniformity is schematically depicted in Figure 4-1. The LED Module under test is placed on a mounting plate large enough to support the LED Module. On top of this, the Uniformity Test Diffuser (UTD) is placed. A luminance camera in sufficiently large distance to avoid image distortion is used to record the appearance of the UTD. A detailed description of the setup is in Annex C.

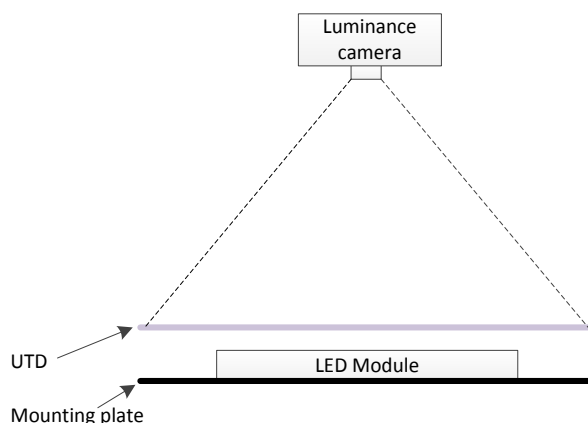

Figure 4-1: Set-up for luminance uniformity measurement.

The recorded luminance image shall be reduced in size to the luminance data area. The luminance data area is a rectangular area with dimensions equal to the dimensions of the Book-7 LLE category of the LLE under test. Note that the size of the luminance data area does not depend on the actual size of the LLE under test. The LED Module shall be in the center of the luminance data area. The resulting image is normalized to its maximum value, leaving all pixel values between 0.0 (no luminance) and 1.0 (maximum luminance).

The data of the luminance data area shall be available in the LLE Product Data Set in two formats:

- A plain-text file with numerical data in geometrical order (number of values in one row and number of rows in the file correspond to the number of pixels in a line and the number of lines in the image respectively). The file shall not contain other data and the data elements shall be separated by a space. The file extension shall be “.txt”.
- A greyscale image. This image shall be an 8-bit greyscale PNG image compliant with [ISO-IEC 15948] and with linear luminance value normalized between 0 (no luminance) and 255 (maximum luminance).

4.6 Correlated color temperature (CCT)

For the purpose of this section, the provisions in [Book 1] - section 4.6, apply.

4.7 Color rendering index (CRI)

For the purpose of this section, the provisions in [Book 1] - section 4.7, apply.

5 Electrical Interface

5.1 Electrical insulation

For the purpose of this section, the provisions in [Book 1] - section 5.1, apply.

It is recommended to specify the implemented electrical insulation according to the applicable standards in the Product Data Set of the LLE.

6 Thermal Interface

6.1 Background information (informative)

In general, one of the most challenging issues in LED lighting is related to the junction temperature of the LED. On the one hand this component is made of a semiconductor material and therefore it is sensitive to operating temperature, both in terms of performance and lifetime. On the other hand the operating temperature of the LED is not only determined by the design of the LLE but also by the design of the Luminaire and by the ambient temperature.

For Book-7 LLEs, the situation is special. Many Book-7 LLEs are very tolerant with respect to the thermal interface. These LLEs are more or less self-cooling. Even when the thermal interface is very poor, these modules do not overheat. On the other hand, some Book-7 LLEs are more demanding with respect to the thermal interface. These LLEs may overheat without special precautions.

6.2 General thermal requirements for Book-7 LLEs

The LLE manufacturer shall indicate in the Product Data Set the position of the temperature measurement point (typically on a hot spot near a LED or a solder point)¹. The temperature that is measured at this point is denoted t_p .

The LLE manufacturer shall list the value of the $t_{p,max}$ in the Product Data Set and this value of $t_{p,max}$ shall be such that if $t_p = t_{p,max}$, a new sample of the LLE (at zero burning hours) shows photometric values equal to the Rated values within tolerances defined in the Zhaga Interface Specification.

The LLE manufacturer shall list the thermal headroom $t_{p,headroom}$ (see section 6.3) in the Product Data Set.

It is recommended to list in the PDS the value of the thermal power of the LED Module (P_{th}) as defined in [Book 1].

6.3 Thermal headroom of Book-7 LLEs

In order to determine the thermal headroom of the LLE, the LLE is mounted in the Test Fixture which is defined in section A.1.3.1.1. Following the test procedure as defined in section A.1.3.1.3, the value of t_p is determined during normal operating conditions (among others at an ambient temperature of 25°C). This value is denoted $t_{p,normal}$. The thermal headroom $t_{p,headroom}$ is derived from $t_p = t_{p,max}$ and $t_{p,normal}$ using EQ. 6-1:

$$\text{EQ. 6-1:} \quad t_{p,headroom} = t_{p,max} - t_{p,normal}$$

The value of the thermal headroom can be used by the Luminaire manufacturer to determine the measures that are required for thermal compatibility. LLEs with $t_{p,headroom} \geq 20$ °C are typically tolerant with respect to the thermal interface when applied in a typical Book-7 Luminaire. No extra tests of the thermal interface are required for this type of LLE.

LLEs with $t_{p,headroom} < 20$ °C are typically more demanding with respect to the thermal interface when applied in a typical Book-7 Luminaire. Without special precautions these LLEs may overheat. LLE manufacturers are recommended to include additional information in the PDS with respect to the thermal interface. And Luminaire manufacturers are advised to use this information and optionally perform additional tests to check thermal compatibility.

¹ This point is different from the measurement point of the Reference Temperature defined in book 1 as the position of t_p is LLE dependent and typically does not lie on the Thermal Interface Surface.

7 Control Interface

For the purpose of this section, the provisions in [Book 1] – chapter 7, apply.

Annex A Compliance tests

A.1 LLE compliance tests

A.1.1 LLE mechanical interface tests

A.1.1.1 Test of the mechanical interface of the LED Module

The purpose of this test is to verify the mechanical interface of the LED Module(s) of the LLE under test.

A.1.1.1.1 Test equipment

The mechanical interface should be tested with a (semi) automated 3D measuring equipment like a non-contact optical measuring system. The measurement accuracy shall be at least $\pm 0,05$ mm.

Alternatively, the mechanical interface may be tested with a gauge made of a material that ensures the accuracy mentioned below (for example 3 mm aluminum). In that case, it shall be verified that the gauge complies with the corresponding demarcation model. This verification shall be done with a (semi) automated 3D measuring equipment like a non-contact optical measuring system. The measurement accuracy shall be at least $\pm 0,05$ mm.

A.1.1.1.2 Test conditions

The mechanical interface shall be verified at 25 ± 5 °C.

A.1.1.1.3 Test procedure

- Determine the designation of the LLE category from the Product Data Set of the LLE under test.
- Find the corresponding LED Module Demarcation in section 3.2.
- Verify that the LED Module(s) under test does not cross the corresponding LED Module Demarcation. Note that such verification includes the outline of the LED Module under test as well as the size, shape and position of the mounting holes within that outline. Additional guidelines for this test are provided in Annex D.

A.1.1.1.4 Pass criteria

The LLE under test passes if the result of the LED Module Demarcation verification is positive.

Using a (semi) automated 3D measuring equipment, verification of the LED Module Demarcation is positive if all measurement points are in the keep-in zone of the LED Module Demarcation with a tolerance of 0,05 mm. Using a gauge, verification of the LED Module Demarcation is positive if the module fits in the gauge.

A.1.1.2 Test of the mechanical interface of the Separate ECG

For the purpose of this section, the provisions in [Book 1] – section A.1.1.2, apply.

A.1.2 LLE photometric interface tests

A.1.2.1 Test of Luminous Flux

The purpose of this test is to verify the Rated luminous flux category of the LLE under test.

A.1.2.1.1 Test equipment

For the purpose of this section, the provisions in [Book 1] – section A.1.2.1.1, apply. The PETF for book-7 LLEs is a temperature controlled heat sink that allows for mounting the LED Module under test and that can be attached to the photometric measurement system.

A.1.2.1.2 Test conditions

See section 4.2.

A.1.2.1.3 Test procedure

- Mount the LED Module-under-test on the PETF. The LES shall be tightly connected to the photometric measurement system.
- In case of an LLE with more than one LED Module, operate the LED Module(s)-not-under-test according to the manufacturer's instructions to enable equal photometric output. If no instructions are provided, the LED Module(s)-not-under-test shall be mounted on temperature controlled test fixture(s), not connected to the photometric measurement system.
- Connect thermocouple(s) to the t_p point(s) of the LED Module(s) at the position defined in the PDS of the LLE and according to the instructions in the PDS of the LLE. In case no instructions are provided, it is recommended to adhere to the instructions in annex K of [IEC 60598].
- Connect the LED Module(s) to the ECG and connect the ECG to the External Power.
- Turn on the power supply.
- Adjust the Ambient Temperature and the heat sink temperature(s) such that, after stabilization (see book 1; section A.1.3.4), all conditions defined in section 4.2 are met.
- Perform the test as described in [IES LM-79-08], Section 9.1.

A.1.2.1.4 Pass criteria

For the purpose of this section, the provisions in [Book 1] – section A.1.2.1.4, apply.

A.1.2.2 Test of correlated color temperature (CCT)

The purpose of this test is to verify the Rated CCT of the LLE under test.

A.1.2.2.1 Test equipment

Use the test setup as described in section A.1.2.1.1.

A.1.2.2.2 Test conditions

See section 4.2.

A.1.2.2.3 Test procedure

Use the procedure in section A.1.2.1.3 to measure the spectral power density (SPD) and calculate CCT according to [ANSI C78.377].

A.1.2.2.4 Pass criteria

For the purpose of this section, the provisions in [Book 1] – section A.1.2.3.4, apply.

A.1.2.3 Test of color rendering index (CRI)

The purpose of this test is to verify the Rated CRI of the LLE under test.

A.1.2.3.1 Test equipment

Use the test setup as described in section A.1.2.1.1.

A.1.2.3.2 Test conditions

See section 4.2.

A.1.2.3.3 Test procedure

Use the procedure in section A.1.2.1.3 to measure the spectral power density (SPD) and calculate the CRI simulating a color plate measurement according to [CIE 13.3].

A.1.2.3.4 Pass criteria

For the purpose of this section, the provisions in [Book 1] – section A.1.2.4.4, apply.

A.1.2.4 Test on luminance uniformity data

The purpose of this test is to verify the presence of graphical data representation of the luminance uniformity in the PDS of the LLE under test.

A.1.2.4.1 Test equipment

None.

A.1.2.4.2 Test conditions

None.

A.1.2.4.3 Test procedure

- Check the presence in the PDS of a plain-text file according to the requirements in section 4.5.
- Check the presence in the PDS of a greyscale image according to the requirements in section 4.5.

A.1.2.4.4 Pass criteria

The LLE under test passes if both the plain-text file according to the requirements in section 4.5 and the greyscale image according to the requirements in section 4.5 are available in the PDS.

A.1.3 LLE thermal interface tests**A.1.3.1 Test of thermal headroom of the LLE**

The purpose of this test is to verify the thermal headroom ($t_{p,headroom}$) of the LLE under test.

A.1.3.1.1 Test equipment

This test shall be conducted with a thermocouple with an accuracy of at least ± 1 K.

Figure A-1 illustrates the Test Fixture used for thermal measurements of the LLE. The Test Fixture consists of a metal frame (Figure A-2), a metal back plate (Figure A-3) and a cover plate (Figure A-4).

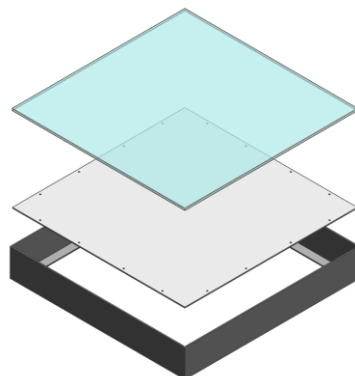

Figure A-1: Test Fixture

The mechanical dimensions of the frame of the Test Fixture are defined in Figure A-2 and the requirements on these dimensions are listed in Table A-1. The frame is made of steel.

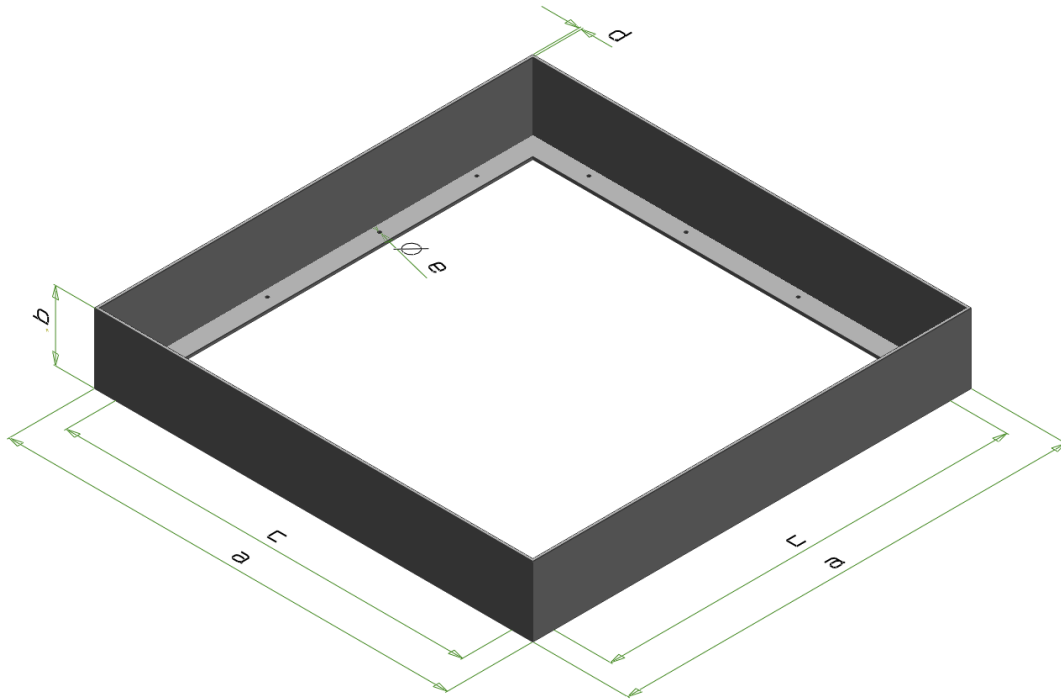

Figure A-2: Mechanical dimensions of frame.

dimension	min	typical	max
a	580	581	582
b	89	90	91
c	528	530	532
d	0,6	0,7	0,8
e	3,3	3,4	3,5

Table A-1: Mechanical dimensions of frame.

The mechanical dimensions of the back plate of the Test Fixture are defined in Figure A-3 and the requirements on these dimensions are listed in Table A-2. The back plate is made of stainless steel 1.4301 (X5CrNi18-10) with white coating and with a thermal conductivity of 15 W/mK +/- 3 W/mK.

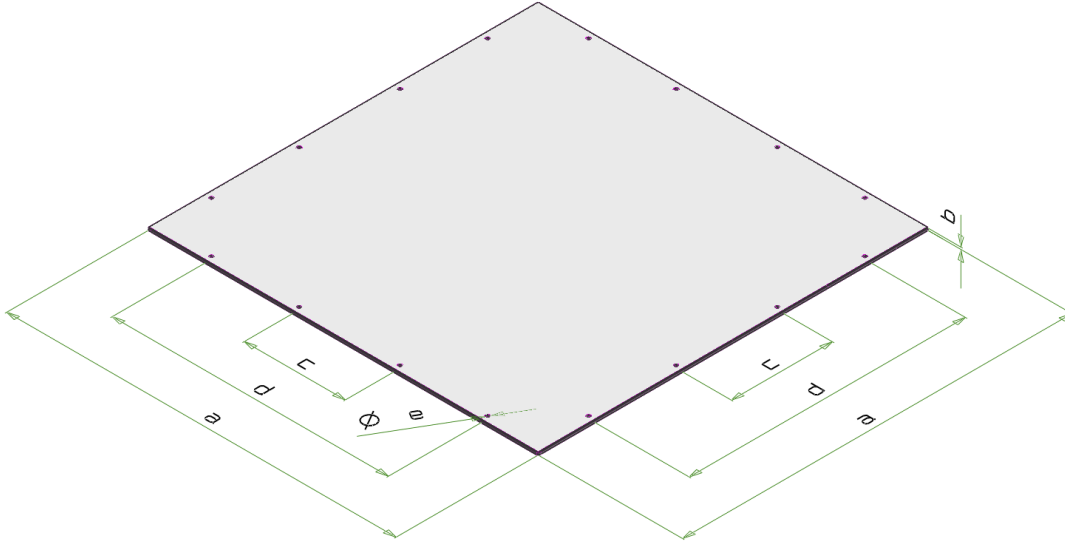

Figure A-3: Mechanical dimensions of back plate.

dimension	min	typical	max
a	575,5	577	578,5
b	1,95	2,00	2,05
c	199,5	200	200,5
d	399,5	400	400,5
e	4,5	4,6	4,7
f	559,5	560	560,5

Table A-2: Mechanical dimensions of back plate.

For mounting the LED Module, the back plate provides holes corresponding to the Book-7 LLE category mechanical specification(s) in section 3 of this book. The position of the LED Module of the mounting plate shall be centered in both directions.

The mechanical dimensions of the cover plate of the Test Fixture are defined in Figure A-4 and the requirements on these dimensions are listed in Table A-3. The cover plate is made of transparent polycarbonate.

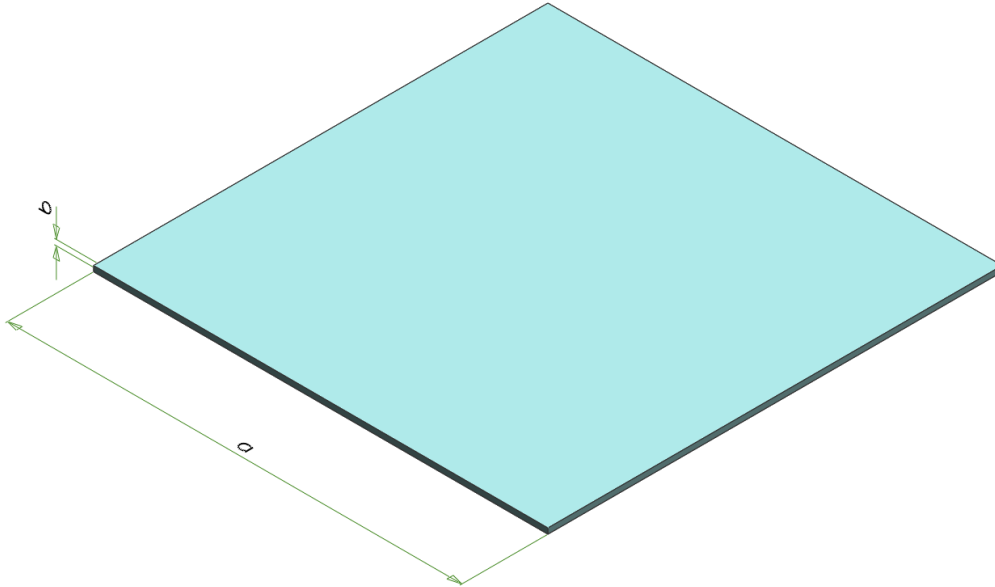

Figure A-4: Mechanical dimensions of the cover plate.

dimension	min	typical	max
a	577	578	579
b	2,5	3	3,5

Table A-3: Mechanical dimensions of the cover plate.

A.1.3.1.2 Test conditions

- The Test Fixture shall be installed in a draught free room with the cover plate facing down and at a distance of at least 50 cm to the floor, to the ceiling and to the walls. The construction to support the Test Fixture shall be as open as possible. Preferably the Test Fixture is suspended.
- The Ambient Temperature shall be within the range 25 ±5 °C and stable within the range ±1 °C.
- The voltage and frequency of the External Power of the LLE shall be within 0,2 % of the Rated values.
- The photometric output of the LLE shall not be affected in any way by objects (reflectors, glass or plastic windows, heat sink features, etcetera) that are exterior to the LLE or the Test Fixture.
- The ECG shall be mounted at a distance from the LED Module such that the ECG does not influence the results of the measurement.
- In case the LLE consists of more than one LED Module, this measurement shall be conducted with one LED Module mounted in the Test fixture, while the other LED Modules are operated outside the Test Fixture.

A.1.3.1.3 Test procedure

- Attach a thermo couple to the LED Module at the t_p -point specified in the PDS.
- Mount the LED Module in the Test Fixture accounting to the instructions in the PDS.
- Install the Test Fixture in a draught free and temperature controlled room.
- Turn on the LLE and wait for stabilization of the temperature t_p (see book 1, section A.1.3.5).
- Measure the value of t_p and normalize it to an Ambient Temperature of 25 °C:

$$t_{p,\text{normal}} = t_p + 25\text{ °C} - t_a$$

- Calculate $t_{p,\text{headroom}}$ according to EQ. 6-1.

A.1.3.1.4 Pass criteria

The LLE under test passes if the calculated $t_{p,\text{headroom}}$ is not less than the Rated $t_{p,\text{headroom}} - 4\text{ °C}$.

A.1.4 LLE electrical interface tests

This edition of Book 7 of the Zhaga Interface Specification does not contain compliance tests for the electrical interface of the LLE.

A.1.5 LLE control interface tests

This edition of Book 7 of the Zhaga Interface Specification does not contain compliance tests for the control interface of the LLE.

A.1.6 LLE Product Data Set test

For the purpose of this section, the provisions in [Book 1] – section A.1.6, apply.

A.2 Luminaire compliance tests

A.2.1 Luminaire mechanical interface tests

A.2.1.1 Test on the mechanical interface of the Luminaire for mounting the LED Module(s)

The purpose of this test is to verify the mechanical LED Module interface of the Luminaire under test.

A.2.1.1.1 Test equipment

The mechanical interface should be tested with a (semi) automated 3D measuring equipment like a non-contact optical measuring system. The measurement accuracy shall be at least +/- 0,05 mm.

Alternatively, the mechanical interface may be tested with a gauge made of a material that ensures the accuracy mentioned below (for example 3 mm aluminum). In that case, it shall be verified that the gauge complies with the corresponding demarcation model. This verification shall be done with a (semi) automated 3D measuring equipment like a non-contact optical measuring system. The measurement accuracy shall be at least +/- 0,05 mm.

A.2.1.1.2 Test conditions

The mechanical interface shall be verified at 25 ± 5 °C.

A.2.1.1.3 Test procedure

- Determine the designation of the LLE category from the Product Data Set of the Luminaire under test. Note that if the Product Data Set of the Luminaire under test lists multiple LLE categories, the next steps shall be repeated for each of the listed LLE categories.
- Find the corresponding Luminaire Demarcation in section 3.2.
- Verify that the Luminaire under test, including mounting means such as screws does not cross the corresponding Luminaire Demarcation. Additional guidelines for this test are provided in Annex D.

A.2.1.1.4 Pass criteria

The Luminaire under test passes if the result of the Luminaire Demarcation verification is positive for all LED Module positions in the Luminaire and for all LLE categories listed in the PDS.

Using a (semi) automated 3D measuring equipment, verification of the Luminaire Demarcation is positive if all measurement points are in the keep-in zone of the Luminaire Demarcation with a tolerance of 0,05 mm. Using a gauge, verification of the Luminaire Demarcation is positive if the gauge fits in the LED module position in the Luminaire.

A.2.1.2 Test on the mechanical interface of the Luminaire for mounting the Separate ECG

For the purpose of this section, the provisions in [Book 1] – section A.2.1.1, apply.

A.2.2 Luminaire photometric interface tests

This edition of Book 7 of the Zhaga Interface Specification does not contain compliance tests for the photometric interface of the Luminaire.

A.2.3 Luminaire electrical interface tests

This edition of Book 7 of the Zhaga Interface Specification does not contain compliance tests for the electrical interface of the Luminaire.

A.2.4 Luminaire thermal interface tests

This edition of Book 7 of the Zhaga Interface Specification does not contain compliance tests for the thermal interface of the Luminaire.

A.2.5 Luminaire control interface tests

This edition of Book 7 of the Zhaga Interface Specification does not contain compliance tests for the control interface of the Luminaire.

A.2.6 Luminaire Product Data Set test

For the purpose of this section, the provisions in [Book 1] – section A.2.6, apply.

Annex B Product Data Set Requirements

In this section the requirements with respect to the Product Data Sets of Zhaga products defined in this Book 7 are listed.

B.1 LLE Product Data Set

The LLE Product Data Sets shall contain the following information:

- the Book-7 LLE category designation
- Designation(s) of the ECG housing(s) according to [Book 1]
- Number of LED modules in the LLE
- Luminous flux category at Rated $t_{p,max}$.
- CCT category at Rated $t_{p,max}$.
- CRI at Rated $t_{p,max}$.
- A plain-text-file with a format as defined in section 4.5.
- A greyscale image with a format as defined in section 4.5.
- the position of the temperature measurement point t_p
- the value of the $t_{p,max}$
- the value of $t_{p,headroom}$

B.2 Luminaire Product Data Set

The Luminaire Product Data Sets shall contain the following information:

- the designation(s) of the Book-7 LLE categorie(s) that can be accommodated in the Luminaire. For each category, the Luminaire Product Data Set shall also show the number of modules that can be accommodated.
- List of Designations of ECG housings according to [Book 1] that can be mounted in the Luminaire. Two designations that only differ in "Height" (for example 'ZC1 H3 (D/S)' and 'ZC1 H5 (D/S)' shall only be indicated once in the list, using the designation with the maximum height ('ZC1 H5 (D/S)' in the example).

Annex C Measurements on Luminance uniformity (informative)

In this annex, a detailed description is given of the measurement of luminance uniformity of book-7 LLEs. LLE manufacturers should use this information for generating the luminance uniformity related data in the PDS of the LLE.

C.1 Test equipment

The measurement setup for this test is depicted in Figure C-1.

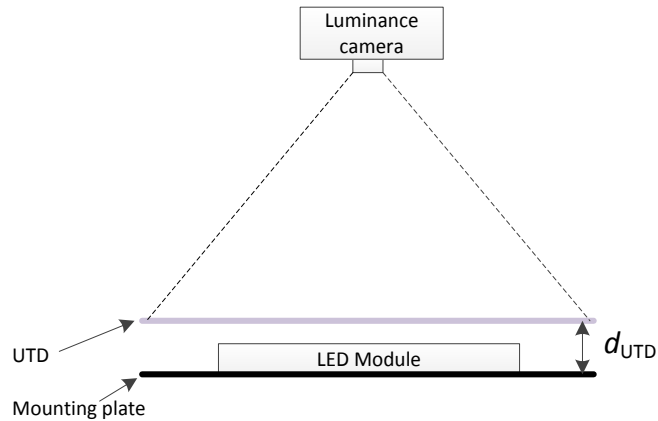

Figure C-1: Set-up for luminance uniformity measurement.

The LED Module under test is placed on a mounting plate large enough to support the LED Module. On top of the LED Module, the Uniformity Test Diffuser (UTD) is placed. This diffuser shall have similar optical properties as a 3mm thick translucent plastic sheet, with a scattering angle (FWHM) of 40° to 50° for normal incident light (for example Evonik DF23 7H)². The UTD shall extend beyond the luminance data area (see section 4.5). The UTD shall be mounted at least a distance equal to d_{UTD} in every direction coplanar to the mounting plate.

The distance between mounting plate and UTD (d_{UTD}) shall be 20 mm (independent of the dimensions of the LED Module)³.

A luminance camera shall be placed at a distance to the UTD of at least 1 times the largest elongation of the luminance data area. A typical distance of at least 1,00 m is recommended. The optical axis of the luminance camera shall be aligned with the geometrical center of the module under test.

The luminance camera shall be aimed at the LED Module, and record local luminance with a resolution of at least 2 pixel per mm in each dimension (i.e. at least 4 pixels per mm² with square pixels).

C.2 Test conditions

- It is assumed that ambient conditions like temperature, humidity do not significantly affect the measurement result.

² This special test diffuser has been chosen to reduce peak luminance of the LEDs, similar as in a typical luminaire situation. The diffusing angle and back scattering are relatively low, to make the set up geometrically robust and minimize the effect of a reflective LED Module surface.

³ This rather low value (compared to a typical Book-7 luminaire, which has a distance of 50mm to 90mm) was deliberately chosen to get a better visible and better distinguishable outcome of the measurement.

- The LED Module shall be mounted on the mounting plate according to the manufacturer's mounting instructions.
- The voltage and frequency of the external power of the LLE shall be within 0,2 % of the Rated values.
- The photometric output of the LED Module shall not be affected in any way by objects (reflectors, glass or plastic windows, heat sink features, etcetera) that are exterior to the LED Module.
- The ECG shall be mounted at a distance from the LED Module such that the ECG does not influence the results of the measurement.

C.3 Test procedure

- Mount the LED Module on the mounting plate and operate it according to the manufacturer's instructions.
- Place the UTD in the distance d_{UTD} from the mounting plate.
- Adjust the luminance camera such that
 - the optical axis is at center of LED Module
 - the luminance camera is focused onto the UTD
 - the luminance camera captures at least the luminance data area.
 - no pixels are overexposed
 - camera noise is minimal.
- Make a luminance image.
- Format the luminance image data.
 - Crop all data beyond the luminance data area.
 - Normalize the resulting image to its maximum value, leaving all pixel values between 0,0 (no luminance) and 1,0 (maximum luminance).
 - Depending on the luminance resolution of the luminance camera, the luminance values can be rounded. A minimum resolution of two significant digits is recommended.
 - Generate a plain-text file according to the requirements in section 4.5.
 - Generate a greyscale image according to the requirements in section 4.5.

Annex D Guidelines for mechanical interface test (informative)

The procedure for the compliance test on the mechanical interface of the LED Module or the Luminaire requires the verification that the LED Module or the Luminaire does not cross the corresponding LED Module/Luminaire Demarcation. Such verification can be performed using (semi-)automated 3D measuring equipment like a non-contact optical measuring system. This annex provides some guidelines on the number of measurement points and their positions to be used for such verification. The example in Figure D-1 will be used to provide these guidelines.

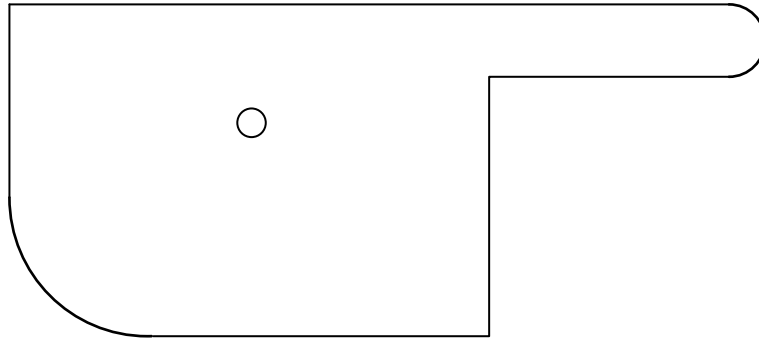

Figure D-1: Example of a LED Module.

As a first step, the outline of the LED Module (including mounting holes) is divided into segments with approximately equal curvature. In each section x , the minimum curvature in that section is denoted by r_x .

As a second step, measurement points are defined at the boundaries between sections. The result of these steps is shown in Figure D-2.

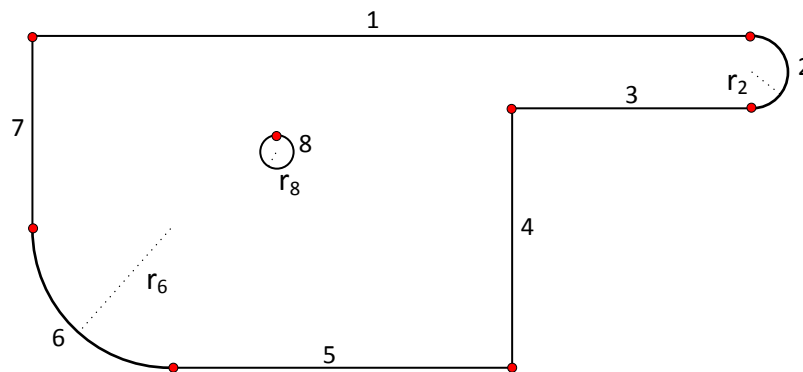

Figure D-2: Example of a LED Module with sections

As a third and final step, each section is divided in sub-sections with a maximum length d with the value of d fulfilling the following requirements:

- $d \leq \frac{r_x}{2}$ and
- $d \leq 10 \text{ mm}$

Additional measurement points are defined at the boundaries of these subsections. The result of these steps is shown in Figure D-3.

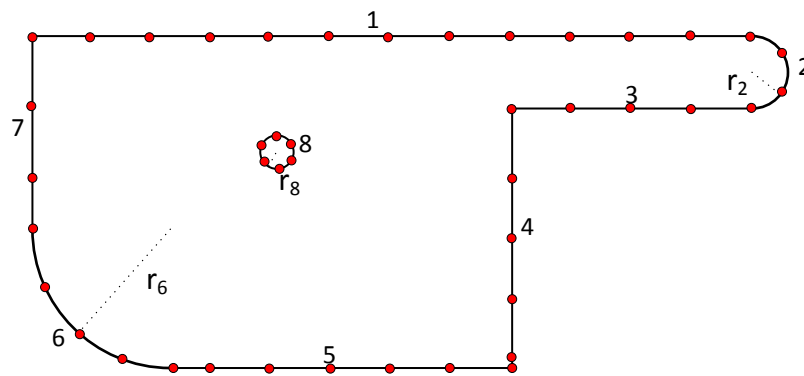

Figure D-3: Example of a LED Module with measurement points.

Annex E History of Changes

Location	Change	Reason
3.2.6	Add new LLE category L38W38	
3.2.7	Add new LLE category L56W56	
4.3	Align Flux category names with [book-1]	

Table D-1: Changes from Edition 1.2 to Edition 1.3.